

# PRIODOC 30

Light file/document cabinets

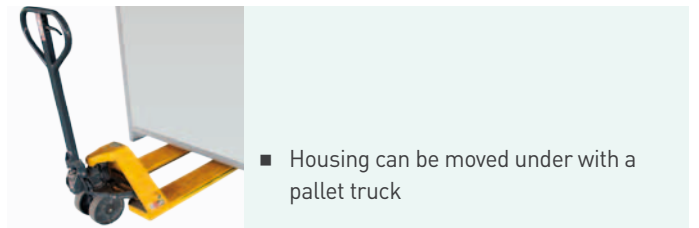
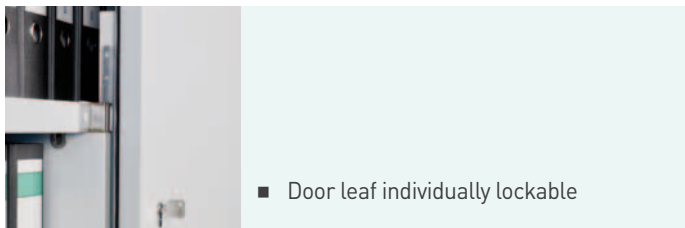
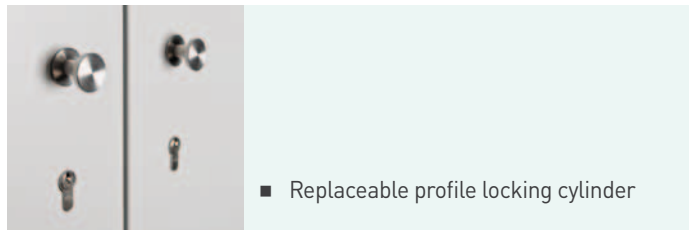
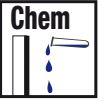

Light fire protection cabinet for secure file and document storage - versatile use. Built for storing large amounts of confidential documents and records worth protecting. The ECB-S certification guarantees quality and safety of the cabinets according to European standards.

## Function

- LFS 30 P classification according to EN 15659
- ECB-S certified double-leaf cabinet
- Smoke protection

## Construction

- Single-layer solid wall construction of homogeneous material
- Double-leaf cabinet, doors can be individually and independently opened and closed
- Doors close flush with body, opening angle ca. 180°
- Locking system with single cylinder
- Locks in a striker plate that is mounted on the centre shelf
- Smoke and fire seals, automatically expand in case of fire
- Shelves are adjustable in height with a spacing of 32 mm
- Protection against external influences from dust and dirt
- Space for jack lifts under the base, height 90 mm with removable front panel

## Material characteristic

- Homogeneous building material, single-layer structure
- Standard surface CPL
- Standard surface light grey, similar to RAL 7035, with ABS edges
- Easy to clean

## Scope of delivery

- PRIODOC 30 filing cabinet fully assembled on pallet

## Options and accessories

- Other surfaces on request



- Centre panel and suspension file drawer

## Standard design

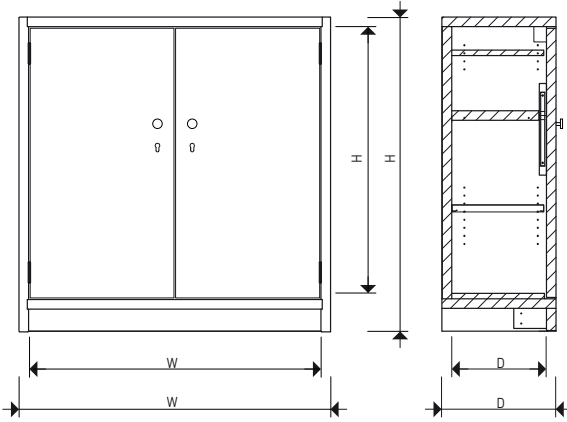



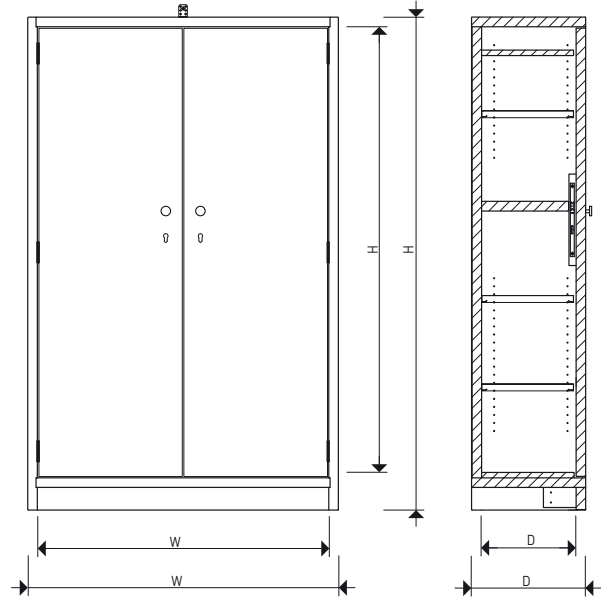
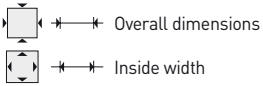

AS32-124-123

1 shelf



AS32-196-123

3 Shelves

Art.	 H x W x D mm	 H x W x D mm	 kg	 Quantity	 kg
<b>Filing and document cabinet, double-leaf AS32 – Standard design</b>					
AS32-124-123	1060 x 1160 x 376	1248 x 1236 x 454	145	1	75
AS32-196-123	1773 x 1160 x 376	1961 x 1236 x 454	209	3	
<b>Filing and document cabinet, double-leaf AS32 – Empty case for individual equipment (see accessories)</b>					
AS32-124-123-0	1060 x 1160 x 376	1248 x 1236 x 454	135	-	-
AS32-196-123-0	1773 x 1160 x 376	1961 x 1236 x 454	195	-	-

Text for invitation to tender can be found at: [www.priorit.de](http://www.priorit.de)

Art.	Accessories
<b>Supplementary equipment for file and document cabinet AS32 with centre wall</b>	
AS32-196-MW-0	Centre wall top including fixings for AS32-196-123-0
AS32-196-MW-U	Centre wall bottom including fixings for AS32-196-123-0
AS32-124-MW-0	Centre wall top including fixings for AS32-124-123-0
AS32-124-MW-U	Centre wall bottom including fixings for AS32-124-123-0
AS32-FB0-S	Additional shelves
AS32-HRA-S	Vertical filing drawer including drawer guides
AS32-KB-MW	Structural shelf top including fixings <sup>1)</sup>
<b>Supplementary equipment for filing and document cabinet AS32 without centre wall</b>	
AS32-FB0-B	Additional shelves
AS32-HRA-B	Vertical filing drawer including drawer guides

<sup>1)</sup> Structural shelves (AS32-KB-MW) must be installed for subsequently mounted centre wall tops to maintain the ECB-S certification, which are already integrated in the standard version without centre wall.

### Design variants for AS32-124-123-0 (Selection)

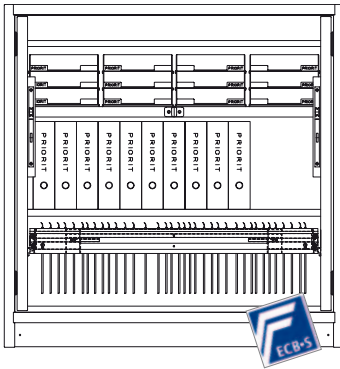

1 Shelf, 1 Vertical filing driver

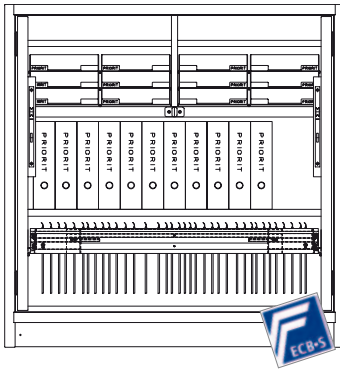

1 Shelf, 1 Vertical filing driver, centre wall top

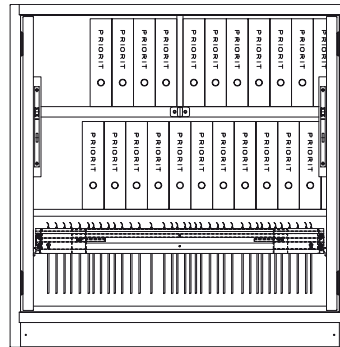

1 Shelf, 1 Vertical filing driver, centre wall top, without door closer

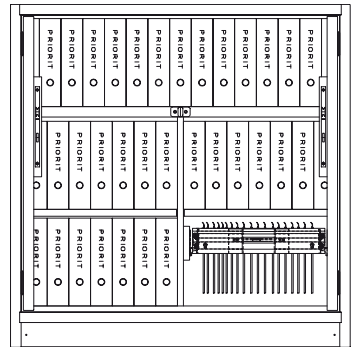

2 Shelves, 1 Vertical filing driver, centre wall bottom, without door closer

### Design variants for AS32-196-123-0 (Selection)

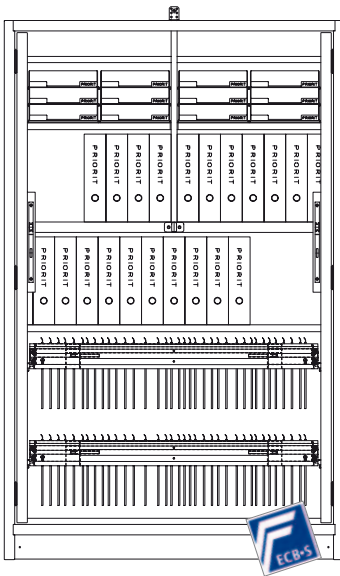

3 Shelves, 2 Vertical filing drawers, centre wall top

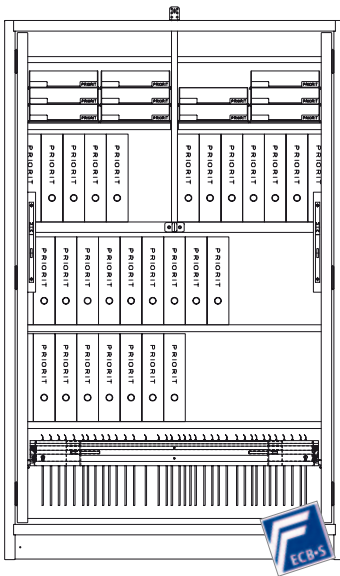

4 Shelves, 1 Vertical filing drawer, centre wall top

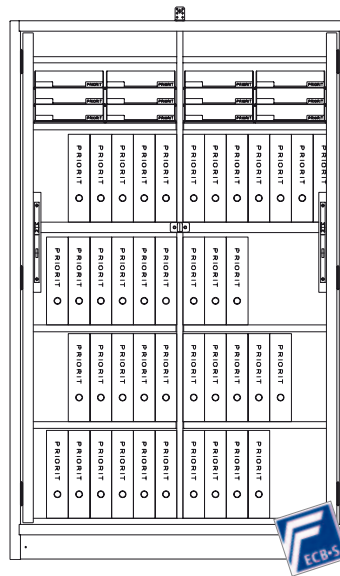

6 Shelves, centre wall

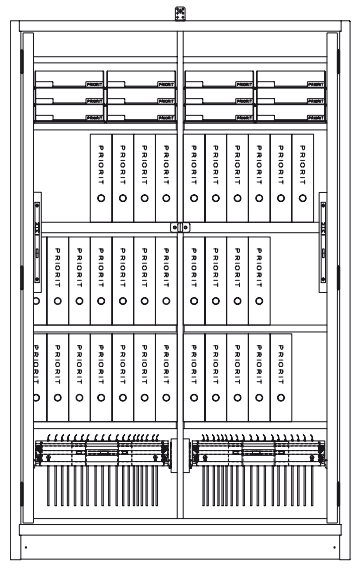

6 Shelves, 2 Vertical filing drawers, centre wall